

TM  
9-1580

TM 9-1580

6 Jun 41

WAR DEPARTMENT

TECHNICAL MANUAL



ORDNANCE MAINTENANCE  
BATTERY COMMANDER'S  
TELESCOPE, M1915A1

June 6, 1941

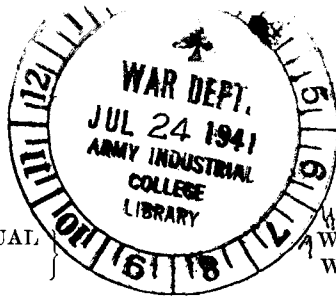

133  
TM 9-1580

1

TECHNICAL MANUAL  
No. 9-1580

U.S.  
WAR DEPARTMENT,  
WASHINGTON, JUNE 6, 1941.

ORDNANCE MAINTENANCE

BATTERY COMMANDER'S TELESCOPE, M1915A1

Prepared under direction of the  
Chief of Ordnance

SECTION I. General.	Paragraph
Purpose -----	1
Scope -----	2
References -----	3
II. Description and operation.	
Description -----	4
Operation -----	5
Accessories and equipment -----	6
III. Inspection.	
Procedure -----	7
IV. Maintenance and repair.	
Tools for maintenance and repair -----	8
Disassembly and assembly -----	9
V. Care and preservation.	
Care in handling -----	10
Optical parts -----	11
Lubrication -----	12
APPENDIX. List of references -----	21

SECTION I

GENERAL

Purpose -----	Paragraph
Scope -----	1
References -----	2
	3

1. **Purpose.**—This manual is published primarily for the information and guidance of ordnance maintenance personnel.

**2. Scope.**—This manual supplements the Technical Manuals which are prepared for the using arm. It contains general descriptive matter and detailed instructions for maintenance and repair of the instruments by ordnance personnel. Figures which accompany the text show the placement and method of fastening of each of the component parts of the telescope.

**3. References.**—The appendix refers to all Standard Nomenclature Lists and other publications pertaining to the instrument.

SECTION II

DESCRIPTION AND OPERATION

	Paragraph
Description .....	4
Operation .....	5
Accessories and equipment .....	6

**4. Description.**—*a.* The battery commander's telescope is a binocular observation instrument for use in measuring angles in azimuth and site.

*b.* The telescope is formed with two prismatic telescope assemblies of similar optical characteristics. These telescope assemblies may be rotated laterally from the vertical position, as shown in figures 1 and 2, to a horizontally spread position. When the telescope assemblies are in the vertical position the line of sight is approximately 12 inches above eyepiece level, permitting periscopic observation. When the telescope assemblies are horizontally spread, the distance between objective prisms is about ten times that between eyepieces, so that objects viewed in this manner are brought into strong stereoscopic relief.

*c.* Each telescope assembly can be focused independently by means of diopter scale, A34010, on each eyepiece. The distance between eyepiece center (interpupillary distance) can be varied to suit the eye spacing of the individual observer. Amber filters, A46320, are supplied for use when observing into sun or searchlight glare, and are attached to the eyepieces by pushing the split ends of the filter holders, A46565, over the eye guards, A34009. The sunshades, B136698, are attached to the objective ends of the telescope assemblies by pushing the split ends into the objective window cells, A46553. The right telescope assembly contains a reticle, B129257, inscribed with a horizontal and a vertical line forming a cross which indicates the optical axis of the telescope. The horizontal line is graduated in 5-mil intervals, 30 mils each side of center. Above the horizontal line are two short lines spaced 3 mils apart for convenience in observing fire.

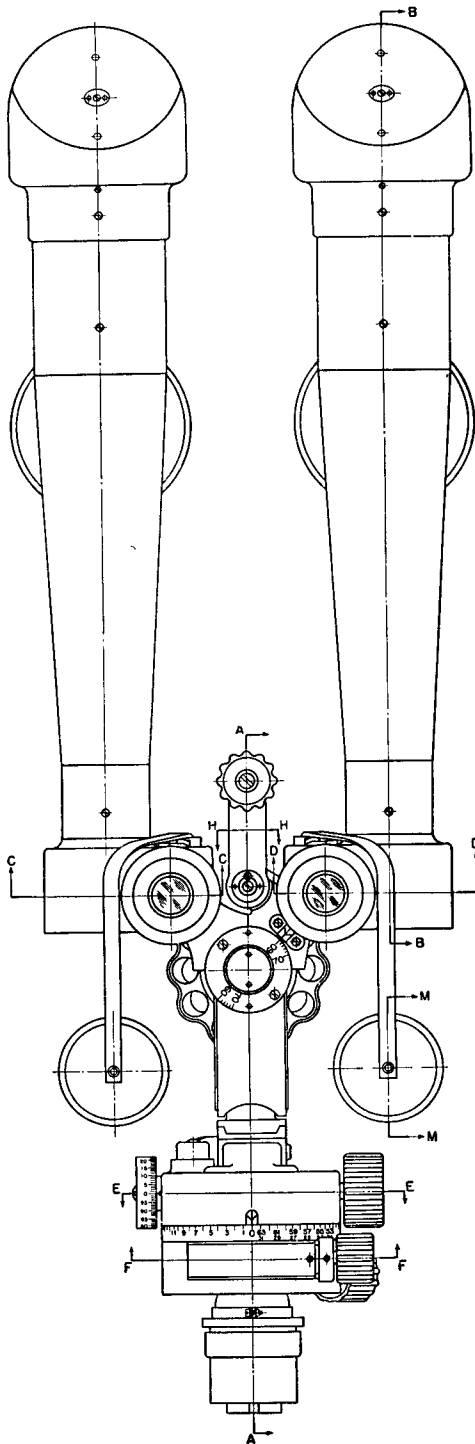

FRA. 367

FIGURE 1.—Battery commander's telescope, M1915A1, rear assembled view.

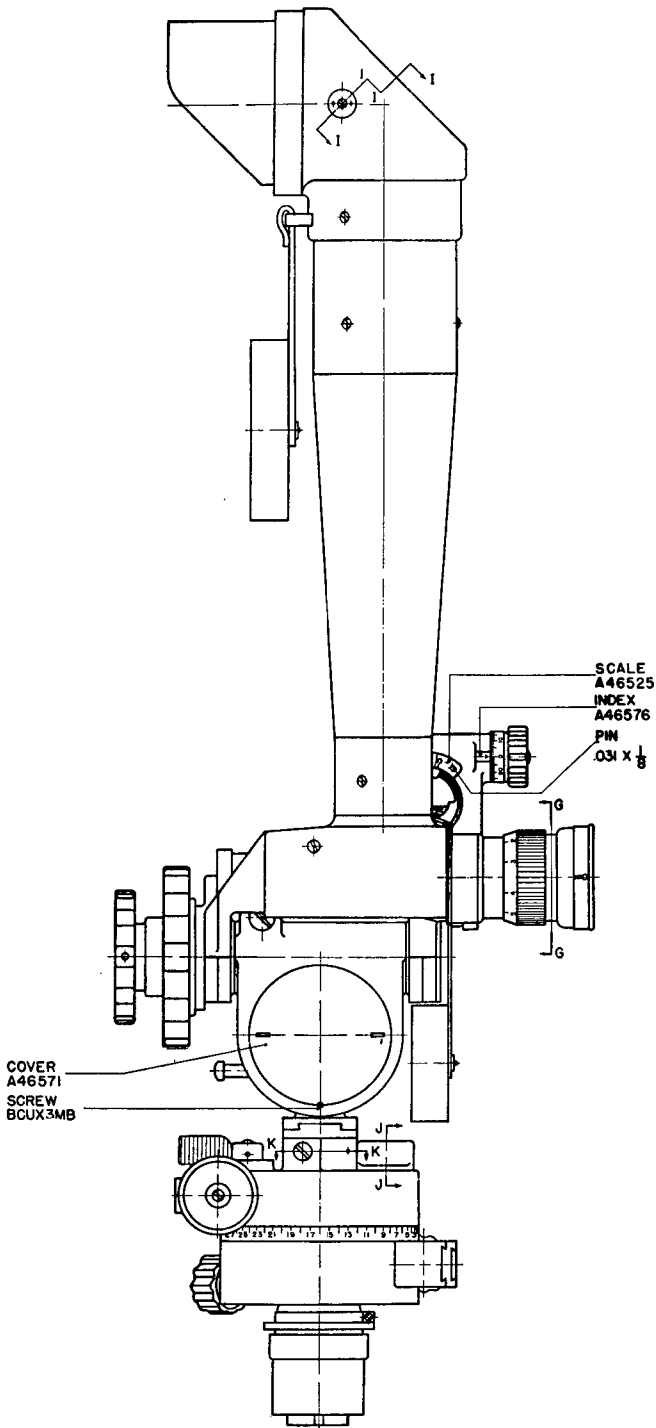

FIGURE 2.—Battery commander's telescope, M1915A1, side assembled view.

The reticle can be erected to suit the position of the telescope by means of the reticle rotating ring, A46305.

*d.* The telescope contains an elevating mechanism and an angle of site mechanism for observations in the vertical plane. It is used in conjunction with the mount, as shown in figures 1 and 2, for observations in azimuth.

*e.* The elevating mechanism is contained in the elevating worm housing, C56990, and is actuated by the elevating worm knob, A46516. The lower portion of the elevating worm wheel, B136699, is fitted with a locating bushing, A46497, and locking plunger, A46498, for securing to the upper vertical spindle, A46542, of the mount.

*f.* The angle of site mechanism consists generally of an angle of site scale, A46525, and micrometer (engraved on knob, A46503) which indicates the vertical angle between the line of sight and the axis of a level vial, A31308. Angle of site indications are in mils and read from 0 to 600. The 300-mil graduation indicates the horizontal position of the line of sight.

*g.* The mount contains the orienting mechanism and azimuth mechanism for directing the telescope in azimuth, and a ball-and-socket joint which is used for leveling in conjunction with the circular level, assembly, B129746. The mount is normally carried in the head bushing of the tripod, type G, and is retained therein by means of a locking screw which passes through the tripod head and engages a drilled hole in the lower vertical spindle bushing, B129429. The upper vertical spindle, A46542, is formed with a locking groove and keyed seat for attachment of the telescope. Azimuth indications are in mils.

*h.* The optical characteristics of the telescope are as follows:

Power (approximate)-----	10X
Field of view-----	4°15'
Diameter of exit pupil-----	.175-inch
Clear aperture of objective-----	1.75-inch
Effective focal length of eyepiece-----	1.155-inch
Effective focal length of objective-----	11.55-inch

*i.* The telescope is designed for reticle illumination in conjunction with instrument light, M1. Illumination may be supplied by flash-light when the instrument light is not available.

**5. Operation.**—*a.* To set up the instrument, remove the tripod and mount from the tripod carrying case, clamp the tripod legs at the desired length, embed them firmly in the ground, and tighten the leg clamping levers. Remove the telescope from its carrying case and

place it on the vertical spindle extending from the mount, depressing the locking plunger and turning the telescope until the mating surfaces of telescope and mount engage properly, then releasing the plunger. Level the mount using the circular level and the ball-and-socket joint

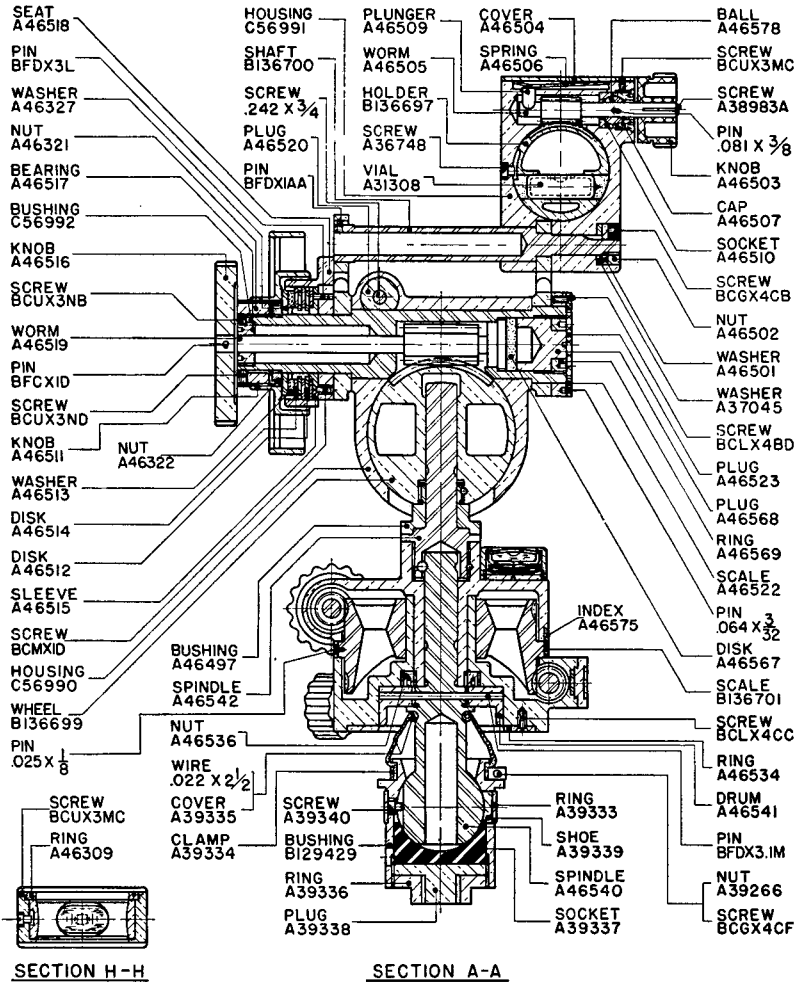

FIGURE 3.—Battery commander's telescope, M1915A1, sectioned views.

at the bottom of the mount and clamp with the tripod head clamping lever when the level bubble is centered.

b. To prepare the telescope, remove the caps from the eyepieces and objectives. If required, place the sunshades over the objectives and the amber filters over the eyelenses; sunshades and filters are carried

in compartments of the telescope case. Release the telescope clamping knob, A46511, and turn the telescope to the vertical or horizontal position as required, at the same time setting the proper interpupillary distance in millimeters on the associated scale, and clamp in place. If

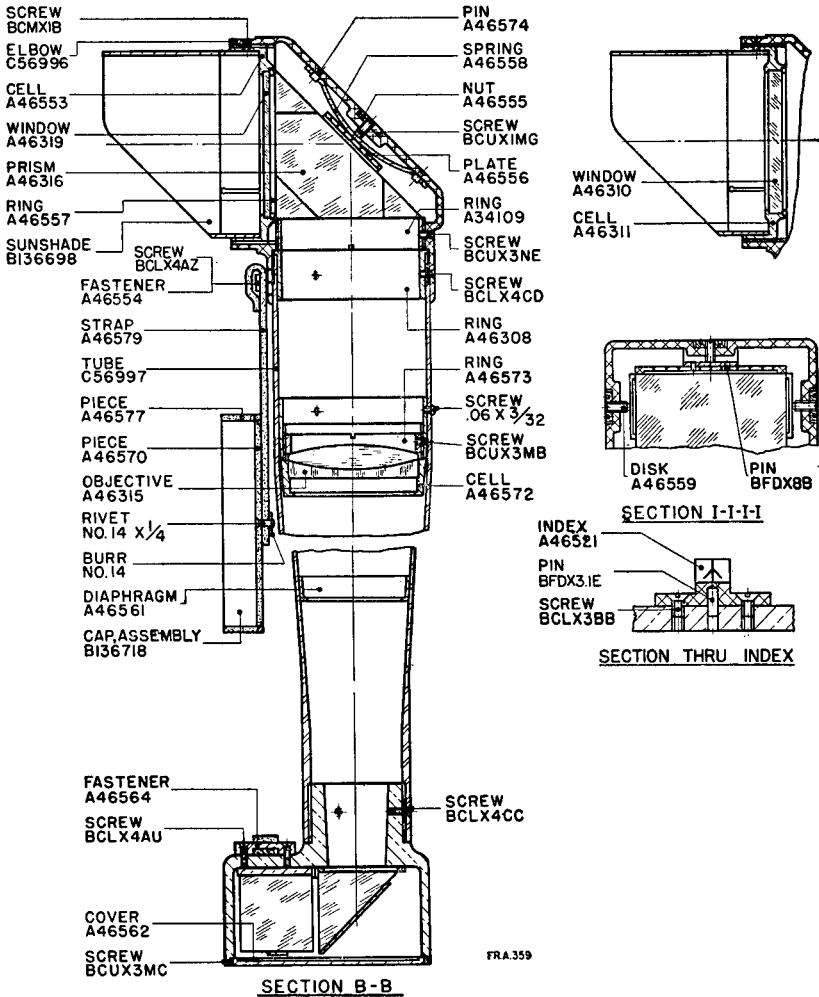

FIGURE 4.—Battery commander's telescope, M1915A1, sectioned views.

the interpupillary distance for the observer is not known, it may be found by observing the sky and moving the eyepieces apart or together until the field of view changes from two overlapping circles to one sharply defined circle. Focus each eyepiece independently,





looking through the telescope with both eyes open at an object several hundred yards away, covering the front of one telescope and turning the diopter scale until the object appears sharply defined, then repeating for the other eye. A diopter scale is provided for each eye

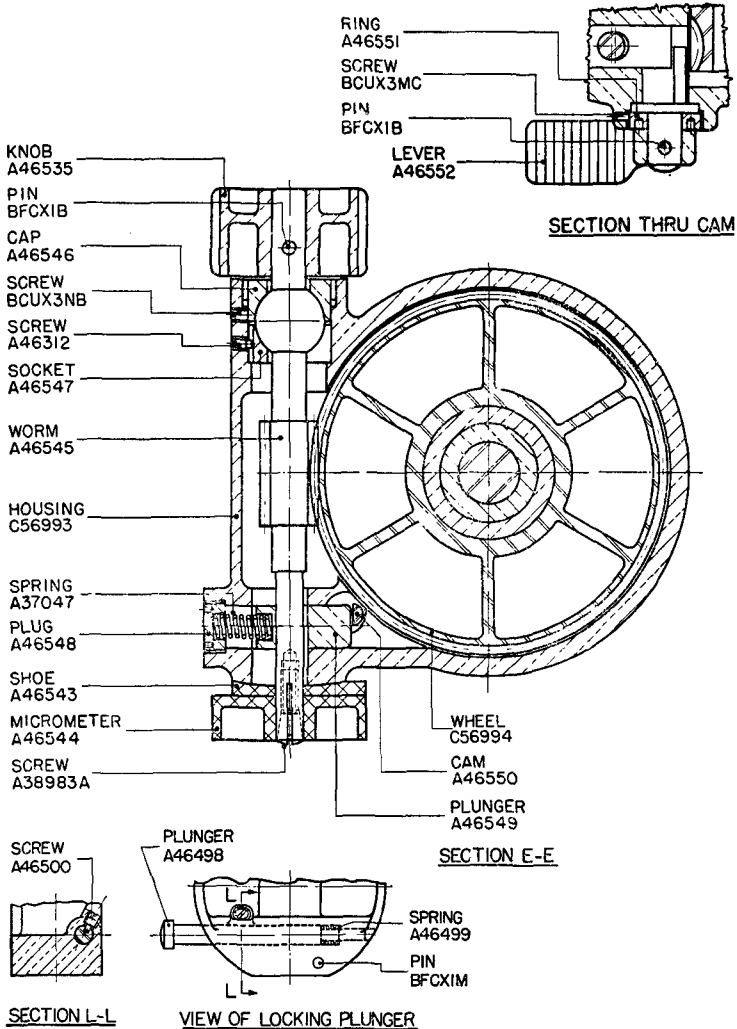

FIGURE 6.—Battery commander's telescope, M1915A1, sectioned views.

and if the observer remembers the values for his own eyes, the settings may be made directly on the scales. Turn the reticle rotating ring until the reticle appears erect.

c. To orient the instrument, select a datum point of known azimuth and set this value on the azimuth scale (100-mil steps) and micrometer (1-mil steps). The throwout lever, A46552, may be used to disengage the worm drive for making large changes in azimuth rapidly. Turn

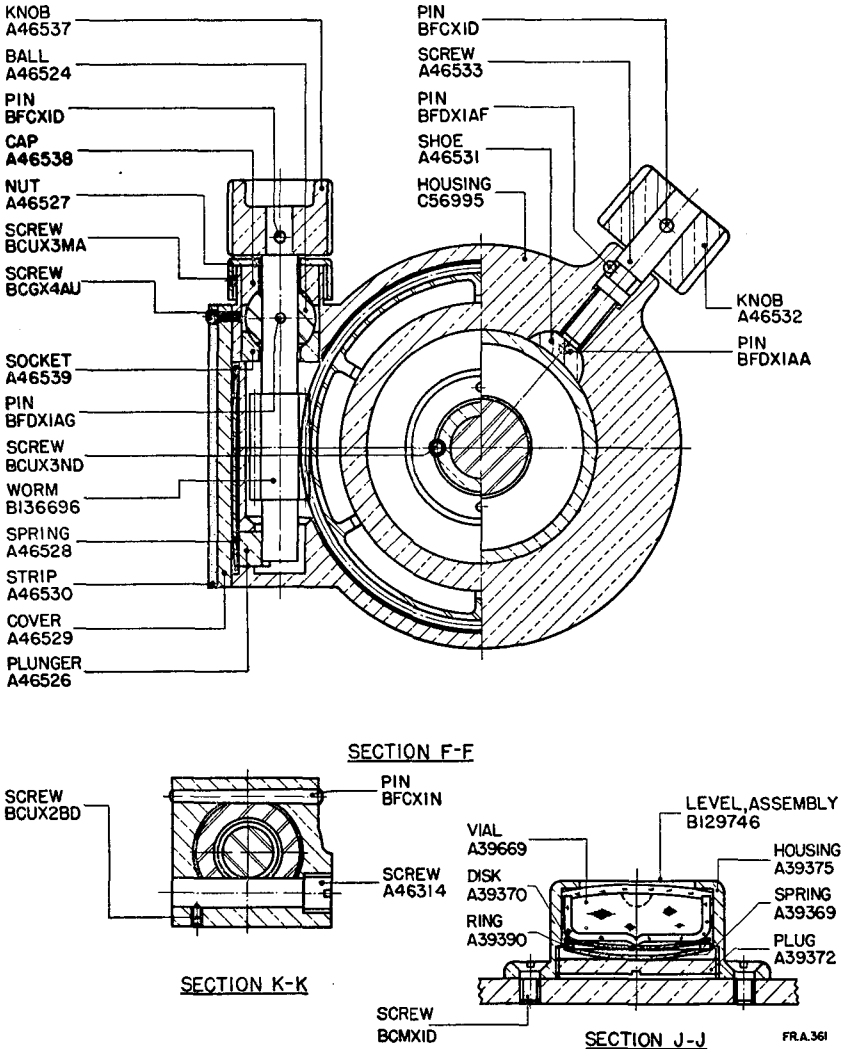

FIGURE 7.—Battery commander's telescope, M1915A1, sectioned views.

the telescope by means of the orienting knob until the datum point appears at the center of the reticle of the right-hand telescope. The orienting clamping screw knob, A46532, may be temporarily released

for making large orienting changes rapidly. After orienting, use only the azimuth knob or, for large changes, the azimuth throwout lever, and the correct azimuth of the point observed will be indicated. For azimuths in the 3200- to 6400-mil region, additional numbers (0 to 3200 mils) are provided, corresponding to the azimuth scales on panoramic telescopes.

*d.* To read angle of site, swing the angle of site mechanism into a substantially vertical plane. Direct the telescope on the object and rotate the elevating knob until the object appears at the center of the reticle. By means of the angle of site knob, center the bubble of the angle of site level in its vial. The angle of site is then read on the angle of site scale (100-mil steps) and micrometer (1-mil steps). An indication of 300 mils corresponds to a horizontal line of sight.

*e.* Small angular indications may be read on the reticle. The horizontal axis of the reticle is graduated at 5-mil intervals for 30 mils on each side of the center. The two short lines above the horizontal line are spaced 3 mils apart.

*f.* To prepare the instrument for traveling, remove the sunshades and filters, if used, and place them in the pockets of the telescope carrying case. Cover the objectives and eyepieces. With the telescope shanks in a vertical position, press the locking plunger and lift the telescope from the mount. Loosen the telescope clamping knob and swing the elevating mechanism against the right- or left-hand telescope. The instrument will then fit snugly into the blocking of the case. The mount need not be removed from the tripod. Tripod leg clamping levers should not protrude.

**6. Accessories and equipment.**—*a. Tripod type G.*—The tripod type G (fig. 8), is issued for use with this instrument. The tripod legs pivot on the tripod head and are clamped against spreading by means of clamping levers. The lower tripod legs slide into the upper tripod legs and are clamped by means of wing nuts. Pointed leg shoes permit embedding the legs in the ground.

*b. Carrying case, M1917A1, for battery commander's telescope, M1915A1.*—A sturdy leather carrying case is provided for the telescope. The case contains pockets for the sunshades and amber filters and clamps for securing the instrument light, M1, and dry cell batteries thereof. The arrangement permits storing the batteries separately from the instrument light to prevent possible damage due to swelling of exhausted batteries.

*c. Carrying case, M1915 and M1915A1, for tripod, type G.*—The carrying case, M1915, consists of a top hood and bottom hood for covering the respective ends of the tripod, fastening straps for

securing the tripod, and shoulder and waist straps for carrying. The carrying case, M1915A1, has an additional leather strap attached to the top hood for use with the 75-mm pack howitzer fire control

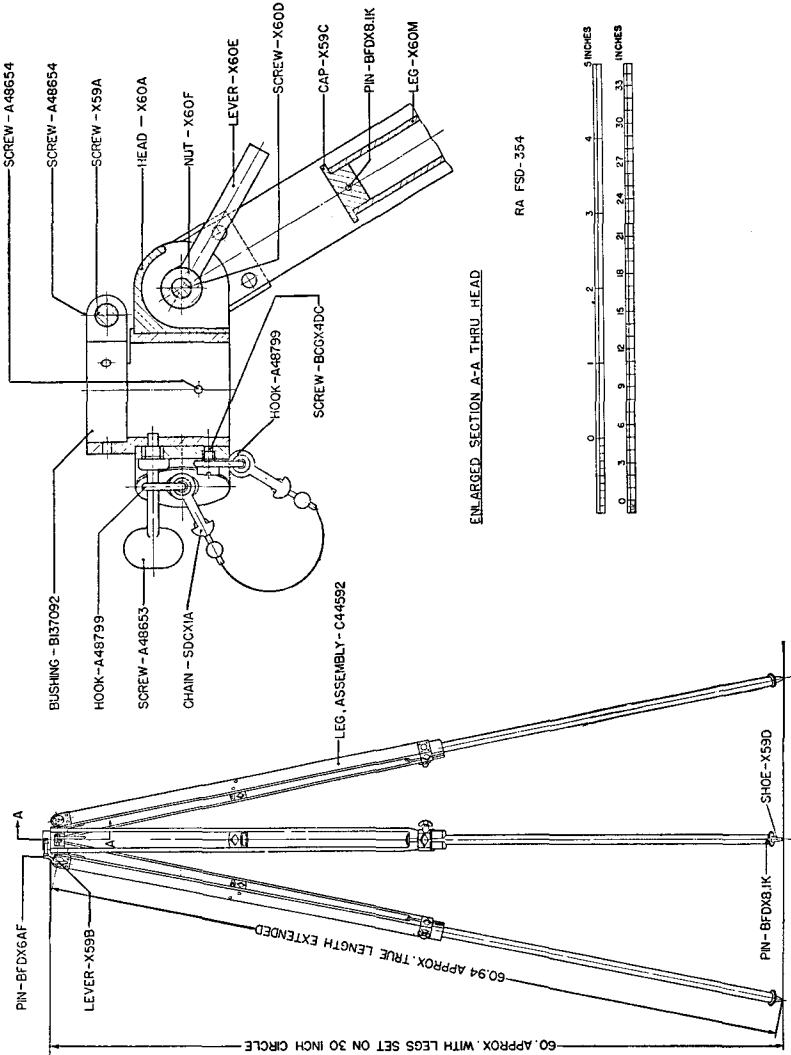

FIGURE 8.—Tripod, type G.

instrument pack load. The mount remains assembled to the tripod when placed in the carrying case.

d. *Brushes.*—A camel's-hair brush and sash-tool brush are provided with the instrument. The camel's-hair brush is used for

removing dry dust from optical parts. Its bristles should be kept clean and dry and should not be allowed to come in contact with oil or grease. The sash-tool brush is oval shaped and has the bristles laid to a chisel edge. It is used for cleaning dust from dry metal surfaces.

*e. Storage chest.*—A wooden storage chest is provided for use in shipment or storage.

*f. Instrument light, M1.*—The instrument light, M1 (not shown), consists of a reticle illuminating unit and an attached hand light for illuminating the level bubble and scales. The hand light is held in a clip on the side of the battery case when not in use. A toggle switch on the bottom of the battery case turns either the reticle or hand light on or off and has a neutral off position for both lights. The electric lamps are commercial instrument lamps of special design rated for 3-volt operation. The lamp bases are the screw-threaded type. The lamps are energized by a single flashlight battery (1.5 volts). Lamp life is high due to low operating voltage.

(1) To remove battery, press down cap on top of battery case and turn until bayonet pins are released. When replacing battery, tip (positive) end should be toward inner contact stud.

(2) To replace electric lamp in hand light, unscrew cap at tip of hand light thereby exposing lamp and socket.

(3) To replace electric lamp in reticle unit, unscrew knurled socket in top of reticle bracket. The lamp is assembled with a lock washer over the tip to prevent loosening.

(4) The flashlight cell is a Signal Corps standard battery, type BA-30. An exhausted cell must not be allowed to remain in the battery case, as it will deteriorate and swell, causing the tube to corrode and making extraction difficult.

### SECTION III

### INSPECTION

Procedure.....	Paragraph
	7

**7. Procedure.**—Inspection is for the purpose of determining the condition of the instrument, whether repairs or adjustments are required, and the remedies necessary to insure serviceability and proper functioning. The listing below will serve as a guide for inspection.

*Parts to be inspected*

- a. Exposed parts.
- b. Optical system.
- c. Alinement of telescopes.
- d. Elevating mechanism.
- e. Angle of site mechanism.

*Points to be observed*

- a. Note damaged or missing parts, loose or missing screws, and general appearance.
- b. Note if checks or frost patterns appear in the field of view. Such defects are evidence of loosening of the balsam used in cementing optical parts and, if severe, may require the return of the instrument to an arsenal for overhaul.
- c. With telescopes vertical and at an interpupillary distance of 64-mm (this is considered the normal setting), sight on a distant object and note the relative position of the image in both fields of view. The comparison can best be made by bringing the image to the edges of the field. Repeat the test with telescopes horizontal. If the images do not occupy substantially the same positions in both fields, the telescopes are out of alinement for binocular vision. Adjustment for this condition is to be performed at an arsenal or base shop.
- d. Elevating knob, A46516, should operate smoothly and without noticeable backlash over operating range. Friction clamp knob, A46511, should operate as intended and provide a smooth friction clamp for the telescopes sufficient to hold the weight of the telescopes in any position.
- e. Direct the telescope on a point at the same level as the telescope objective. Center the angle of site level bubble by means of

*Parts to be inspected**Points to be observed*

- angle of site knob. The "3" graduation of the angle of site scale should then be opposite the index. (Micrometer reading may be disregarded as micrometer adjustment is performed by the using personnel.)
- f.* Spindle engagement. *f.* Try fit of telescope on upper vertical spindle, A46542, of mount. Check functioning of locking plunger, A46498. If parts do not engage easily and lock securely, determine the cause as damaged spindle, worn seat, dirt in socket, etc.
- g.* Azimuth worm parts. *g.* Operate azimuth worm throughout entire range. Check for backlash and longitudinal play. Try functioning of azimuth worm throughout lever.
- h.* Orienting worm parts. *h.* Operate orienting worm throughout entire range. Check for backlash and longitudinal play. Try functioning of orienting clamping screw knob.
- i.* Ball joint on lower vertical spindle, A46540. *i.* When the ball joint is not clamped by the tripod head, the movement should be free enough to allow easy leveling, but not so free as to allow the instrument to fall over. When it is clamped it should hold the telescopes in a rigid leveled position.
- j.* Circular level, assembly. *j.* Level bubble should remain central when telescope mount is traversed through a complete revolution. Extreme accuracy in this level setting is not essential.



SECTION IV

MAINTENANCE AND REPAIR

Tools for maintenance and repair-----	8
Disassembly and assembly-----	9

**8. Tools for maintenance and repair.**—An optical repair kit containing the necessary tools, fixtures, cements, oils, etc., for use with these instruments is furnished to ordnance maintenance companies. A complete list of the items comprising the kit is contained in a blueprint which is fastened in the cover of the chest. Every item in the kit is designated by a number equivalent to the compartment number. Most of the items such as screw drivers, etc., require no description as their uses are self-explanatory. The collimating telescope, No. 90, which is furnished with the kit is an ordinary nonerecting type. It is adjusted for parallax by the usual means of focusing the eyepiece on the cross wires and then removing parallax by focusing the objective, temporarily loosening the draw-tube clamping screw in the side of the telescope for the purpose. The magnifying power of the collimating telescope is 9.78X; the field of view is 4°21'.

**9. Disassembly and assembly.**—Repairs which necessitate disassembling and assembling operations are limited to those which do not affect the optical alinement of the instrument. Repairs involving realinement, removal, or replacement of optical parts, or other repairs which cannot be made with the facilities available, will require that the instrument be turned in to the base shop.

*a. Disassembly and assembly of elevating mechanism.*—(1) Remove elevating worm knob, A46516, by driving out taper pin, BFCX1D. (Fig. 3.)

(2) Remove friction clamp knob, A46511.

(3) Remove round nut, A46321, after releasing screw, BCUX3ND, which secures it.

(4) Remove round nut, A46322.

(5) Remove friction washers and disks. Note sequence of removal so that parts may be replaced in the same order.

(6) This completes disassembly of parts at forward end of worm. If further disassembly is required, continue as follows:

(7) Remove interpupillary scale, A46522, with plug, A46523, if final disassembly is to include removal of eccentric bushing, C56992. Otherwise, the plug alone may be removed without disturbing interpupillary scale.

(8) Unscrew retaining ring, A46569, which secures pressure plug, A46568. Remove pressure plug and disk, A46567.

(9) Loosen or remove screw, 0.242 by  $\frac{3}{4}$  inch, which secures eccentric bushing clamp plug, A46520.

(10) Remove elevating worm, A46519, through rearward end of housing.

(11) Remove elevating worm housing covers, A46571, after removing locking screws, BCUX3MB. Mark right and left covers separately. (Fig. 2.)

(12) Remove locking screw, A46500, which retains locking plunger, A46498. Remove locking plunger and spring, A46499. (Fig. 6.)

(13) Mark position of locating bushing, A46497. Drive out taper pin which secures bushing and remove bushing from worm gear (wheel, B136699). Worm gear may now be removed from housing. (Fig. 3.)

(14) Eccentric bushing, C56992, may now be removed by driving out. This operation should not be performed, however, unless entirely essential as difficulty may be experienced in reassembling.

(15) Assembly of the elevating mechanism is performed in the reverse sequence of disassembly. The adjustments in (16) and (17) below will be required for proper operation.

(16) Adjust pressure plug, A46568, so that elevating worm, A46519, operates smoothly without longitudinal play. Tighten retaining ring, A46569, to secure pressure plug at the correct adjustment setting.

(17) Adjust eccentric bushing, C56992, to eliminate play between worm and worm gear. Tighten eccentric bushing clamp plug screw to secure eccentric bushing at the correct adjustment setting.

*b. Disassembly and assembly of angle of site mechanism.*—(1) *To remove angle of site worm, A46505 (sec. A-A).*—Remove angle of site worm knob, A46503, secured by screw, A38983A. Remove headless screw, BCUX3MC, which secures cover, A46504, and ball cap, A46507. Slide cover out of its dovetail seat. Unscrew ball cap. Remove spring, A46506, and plunger, A46509, which are exposed when cover is removed. Remove angle of site worm with ball, A46578, and ball socket, A46510. (Fig. 3.)

(2) *To remove angle of site level vial holder, B136697 (secs. A-A and H-H).*—Remove screw, BCUX3MC, which secures retaining ring, A46309, and unscrew retaining ring. Remove holder stop screw, A36748. Disengage angle of site worm from worm gear teeth in level vial holder and remove level vial holder.

(3) *To replace angle of site level vial, A31308.*—Remove angle of site level vial holder as described above. Remove old packing and broken glass from level vial cavity. Place new level vial in position, center graduations in opening, and pack level vial lightly in position with paper strips. Secure with calcined gypsum (plaster of paris) which has been mixed to medium consistency. Remove excess plaster from surface after plaster has set.

(4) *Assembly.*—Assembly of the angle of site mechanism is performed in the reverse sequence of disassembly. When replacing angle of site worm ball cap, A46507, tighten cap to a snug fit on the ball, sufficient to take up lost motion but not so tight as to cause binding.

*c. Disassembly and assembly of mount.*—Complete field stripping of the mount is not normally required. The circular level assembly, lower vertical spindle bushing, and worm mechanisms may be removed separately without opening the mount housing. Should it be necessary to open the mount housing, proceed as follows:

(1) Remove vertical spindle retaining screw, A46314, secured by screw, BCUX2BD. Taper pin, BFCX1N, need not be removed unless necessary to remove upper vertical spindle. These parts are shown in sections K-K and A-A.

(2) Drop lower vertical spindle, A46540, out through bottom of mount. Remove ring, A46534, if necessary to allow clearance for drum, A46541. Orienting clamping screw knob must be released to permit removal of spindle.

(3) Remove round nut, A46536, which is exposed after removal of lower vertical spindle. This round nut is secured by a small locking screw.

(4) Disengage azimuth worm from worm gear teeth and pull azimuth worm housing, C56993, free from lower part of mount. Internal parts are now accessible for cleaning or other operations.

(5) Assembly is performed in the reverse sequence of disassembly.

## SECTION V

### CARE AND PRESERVATION

	Paragraph
Care in handling .....	10
Optical parts .....	11
Lubrication .....	12

**10. Care in handling.**—*a.* The telescope should be handled carefully to avoid unnecessary shocks.

*b.* When spreading or folding the telescope assemblies, the telescope clamp knob should be loosened sufficiently to make the use of

undue force unnecessary, as such use of force may bend the telescope tubes and cause overlapping of the images.

*c.* When using the azimuth worm throwout lever, turn the lever sufficiently to prevent scraping of the worm on the teeth of the worm gear. Be careful not to let the worm snap into mesh as that would bur the teeth.

*d.* The objective caps and eyepiece caps should be placed in position to protect the lenses when the telescope is not in use.

*e.* The telescope should be protected from wet weather as much as possible. The exposed parts of the instrument and accessories should be wiped dry as soon as practicable after use in inclement weather, before placing the instrument in the carrying case.

*f.* Exposed metal surfaces of the instrument should be cleaned occasionally with the sash-tool brush.

*g.* Keep the instrument in the carrying case when not in use.

**11. Optical parts.**—*a.* To obtain satisfactory vision, it is necessary that the exposed surfaces of the lenses and other parts be kept clean and dry. Corrosion and etching of the surface of the glass can be prevented or greatly retarded by keeping the glass clean and dry.

*b.* For dusting optical parts, use only a clean camel's-hair brush. For wiping, use only lens tissue which is a paper specially prepared for cleaning optical glass. Use of cleaning cloths in the field is not permitted.

*c.* To remove oil or grease from optical surfaces, apply ethyl alcohol with a clean camel's-hair brush and rub gently with clean lens tissue. If alcohol is not available, breathe heavily on the glass and wipe off with clean lens paper; repeat this operation several times until clean.

*d.* To remove dust, brush the glass lightly with a clean camel's-hair brush and rap the brush against a hard body in order to knock out the small particles of dust that cling to the hairs. Repeat this operation until all dust is removed.

*e.* Do not wipe the lenses or windows with the fingers.

*f.* Moisture due to condensation may collect on the optical parts of the instrument when the temperature of the parts is lower than that of the surrounding air. This moisture, if not excessive, can be removed by placing the instrument in a warm place. Heat from strongly concentrated sources should not be applied directly, as it may cause unequal expansion of parts with resulting inaccuracies in observation.

**12. Lubrication.**—Moving parts should be lubricated sparingly with the lubricants furnished by the Ordnance Department for fire control instruments. The lubricants commonly used are aircraft instrument and machine-gun lubricating oil (U. S. Army Spec. 2-27) of the latest issue in effect, and Royco 6A. Royco 6A is used where a soft or medium grease is required. (See OFSB 6-F-1). No lubricant should be allowed to enter the telescope interiors or come in contact with optical surfaces. The instrument should be kept clean from any excess lubricant.

